



Ophthalmic Squeeze Dispenser

Technology Platform



Aptar 
pharma

From formulation to patient.

Ophthalmic Squeeze Dispenser

The versatile multidose technology platform for preservative-free ophthalmic formulations

Multidose Preservative-Free System Makes Preservatives Obsolete

Preservatives in Eye Care formulations, such as Benzalkonium Chloride (BAC), can lead to side effects with chronic use. The Ophthalmic Squeeze Dispenser represents a worldwide-accepted solution to address this challenge.

Key Benefits

- Purely mechanical Tip-Seal technology eliminates the need for preservatives and additives, such as silver ions or surface coating
- No filtering of formulation
- Metal-free fluid pathway

How the Ophthalmic Squeeze Dispenser works:



By squeezing the bottle ...



... the pressure inside the system rises until the Tip-Seal opens and releases the drop.

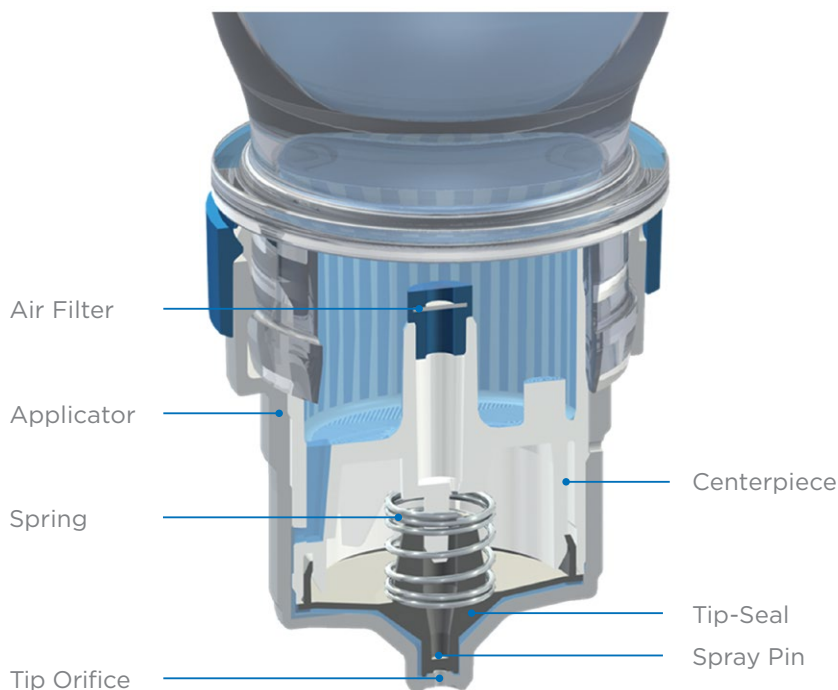

Proven Microbiological Integrity Protects Your Preservative-free Formulation



- Aptar Pharma's Tip-Seal technology has been qualified by microbial challenge tests and has passed relevant worst-case simulation
- Comprehensive data package

TSIT 2.0

(Tip-Seal Integrity Test)

Submersed actuation in challenge suspension containing *Pseudomonas aeruginosa*, *Staphylococcus aureus* and *Candida albicans*. Reflects most recently updated guidelines in highly regulated markets.



CVIT

(Closure Ventilation Integrity Test)

Closure and filter challenge with *Bacillus atropheus* spores in aerosol chamber.



Designed to Comply with Regulatory Standards Your Eye Care Product Has to Fulfill

- The Ophthalmic Squeeze Dispenser (OSD) is designed to comply with the regulatory requirements worldwide
- The OSD meets current FDA recommendations*
- It is the only PFMD technology that is part of an approved system to deliver a prescription ophthalmic drug product in the US**



Aptar Pharma Service Packages Available to Support Development of Preservative-Free Eye Care Products

- Comprehensive data packages available
- Global CMO/CDMO network and excellent equipment vendor contacts
- Experienced Regulatory Affairs team to support registration processes worldwide
- Gold standard analytical lab services

Worldwide Accepted Technology Platform

- Leader in both consumer product and prescription Eye Care medications
- More than 500 references worldwide feature the Ophthalmic Squeeze Dispenser



*www.fda.gov/regulatory-information/search-fda-guidance-documents/quality-considerations-topical-ophthalmic-drug-products

**https://www.accessdata.fda.gov/drugsatfda_docs/nda/2016/50790Orig1s025.pdf

Versatile Technology Platform Offers Easy Customization Solutions for the Ophthalmic Squeeze Dispenser

The technology platform allows for a wide range of customized configurations and applications for specific ophthalmic formulations.



Cap Options

- Standard Cap/Liner Cap/Pure Cap
- Caps available in various colors



Liner Cap

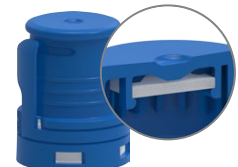

Pure Cap



Functional Options

Flow Control

Wide range of flow control settings for various formulation properties



Pure Pin

Ultra-clean COC material for sensitive formulations



* Illustrated in blue for visualization purposes only.

Filter Protection Valve

TPE one-way duckbill valve designed for media having chemical or physical properties impairing a proper filter function



Container Options*

Standard Bottle

Globally well-established container solution of the first generation

Soft Bottle

Notable squeeze force reduction for easy handling

Pure Bottle

Ultra-clean COC material assures high level of chemical inertness for sensitive formulations



Standard



Soft



Pure

* Available from outside vendors

Versatile Bottle Configurations

- Gamma- or ETO-sterilized
- White or translucent
- Variable container sizes



7ml



10ml

For more information, please visit www.aptar.com/pharma

From formulation to patient.

