

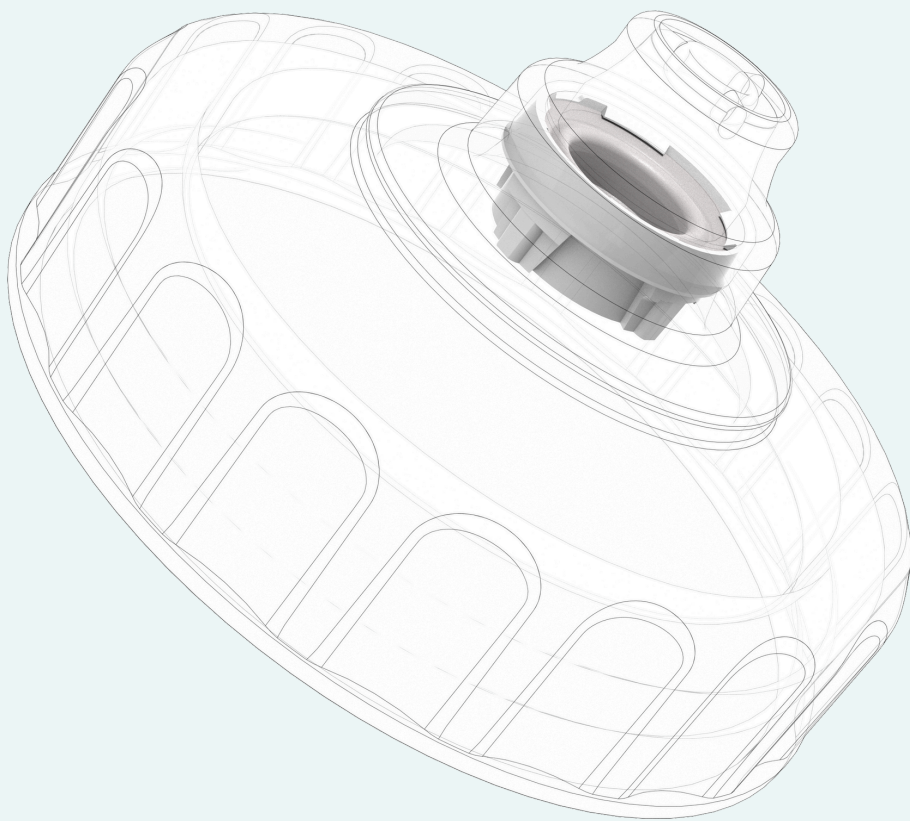

CREATE
COLLABORATE
INNOVATE

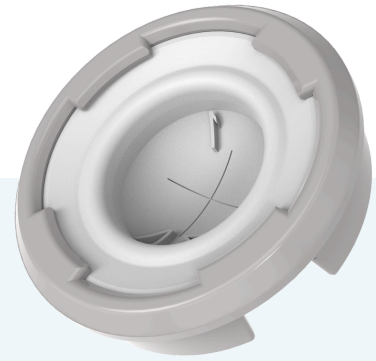

High Performance Valve, Simplified Assembly



SureSnap is a 2-in-1, pre-assembled valve and retaining ring, designed for convenience and high-performance flow control.



SNAP & GO ASSEMBLY

- Faster, simplified assembly process
- Reduced costs: no assembly expertise needed (compared to rubber/silicone alternatives)



ENHANCED CONSUMER EXPERIENCE WITH SIMPLISQUEEZE[®] TECHNOLOGY:

- Controlled and precise dispense
- Prevents drips or leakage for hygienic experience
- Maintains consistent flow control & performance, even after multiple wash cycles
- Upright and inverted packaging compatible



FASTER TIME TO MARKET

- Small minimum order quantity
- Short lead times

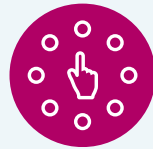

VARIETY OF APPLICATIONS

Various sizes to handle low to high viscosities



Various slit configurations to handle full range of opening pressures and flow rate

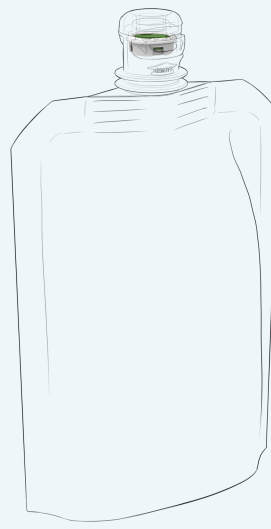
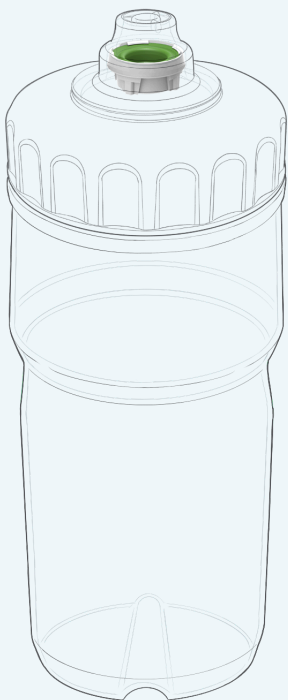

SPECIFICATIONS

Valve Material : Silicone
Ring Material : PP & HDPE
Size : 0.375" (9.5mm) and 0.634" (16.1mm)

PROVEN TECHNOLOGY FOR MULTI-USE/REUSABLE PRODUCTS & MORE

